

Reductores

BLOC

a Sinfin y Corona

✓ Rev: 11-07-2016

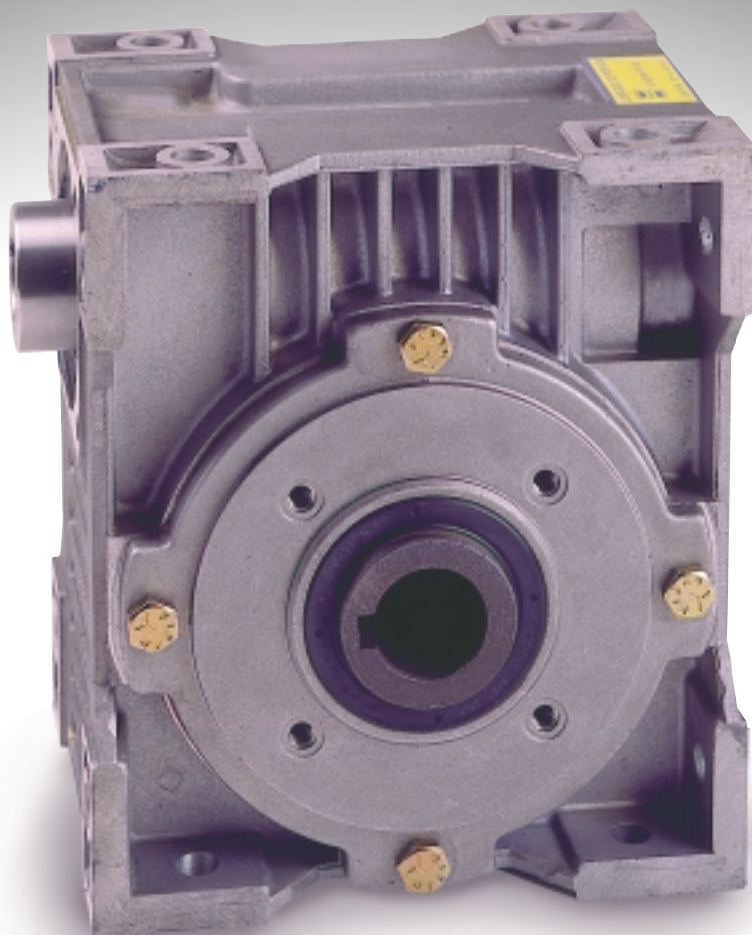

LENTAX

POTENCIA EN ESTADO PURO

Reductores de velocidad

La nueva serie de motorreductores y reductores de sinfín y corona BLOC se caracteriza por el moderno diseño de todos sus componentes. Se ha cuidado especialmente el diseño del cuerpo, construido en aluminio, reduciendo al máximo sus dimensiones y peso, sin disminuir su resistencia y rigidez mecánica. La perfecta construcción, que se obtiene en los procesos de fabricación, le confiere una alta calidad estética que permite su utilización en una amplia gama de aplicaciones, excepto en los casos que se precise una protección muy específica.

Características constructivas

Cuerpo exterior

Fundido totalmente en aluminio, se caracteriza por la forma, que se distingue de las construcciones tradicionales adoptadas en la mayoría de los reductores a sinfín y corona.

Gracias a esta peculiar cualidad y en particular por la posibilidad de ser fijado por cualquiera de sus caras hacen de la línea BLOC, un reductor utilizable totalmente en cualquier aplicación sin ninguna modificación o adaptación en sus dimensiones, como ocurre en otros reductores.

El proceso de fundición, junto con la tecnología de punta y materiales utilizados en su producción y en particular la mecanización de los alojamientos en modernos centros de mecanizado, le confieren una excelente precisión, robustez y fiabilidad. El particular diseño estructural adoptado permite obtener una ventajosa relación peso/potencia, con una alta disipación térmica que permite utilizarlo al máximo de prestaciones, alcanzando temperaturas de trabajo de 85° a 90° C.

Sinfín y corona

Tornillo sinfín construido en acero SAE 1045 y corona de bronce al aluminio, montada en núcleo de hierro, fresada con creadores de igual diámetro que los correspondientes tornillos sinfín.

Capacidades de transmisión

Calculadas según las premisas indicadas por las normas AGMA.

Lubricación

Todos los reductores y motoreductores de la línea BLOC vienen dotados de lubricación de por vida, con el tipo y cantidad adecuado para su normal utilización en cualquier posición de montaje, eliminando así totalmente cualquier operación de mantenimiento.

Speed reducers

The new range of BLOC worm geared motors and BLOC worm gear boxes are characterized by the modern design in all its components. Its careful housing design has been specially made of aluminium which reduce to the maximum its size and weight without decreasing its resistance and mechanical stiffness. The perfect building which is obtained from these manufactured processes, awards it a high aesthetic quality which allows its usage in a wide variety of applications, excepts for those cases that need a very specific protection.

Building features

Gear housing

Wholly melted in aluminium, its shape is distinguished from the traditional buildings adopted in most of the speed reducers.

Thanks to this special quality and particularly for the possibility of being by any of its sides. All it makes BLOC units be able to be entirely used in any of its applications without any change or adaptation on its measures, as it happens with other ones.

The die casting process, together with the latest technology and materials used in its production and particularly the bearing seats which are machined in modern tool-machines, awards them high precision, power and reliability. This particular design allows to obtain an advantage between power to weight ratio and high thermal conductivity which ensures an optimum performance reaching temperatures of 85° - 95° C.

Worm gears

Worm made of steel SAE 1045 and cast bronze rim on cast iron center. Hobs with diameters according to the corresponding worms.

Gearing capacity

It is calculated under all A.G.M.A. standard.

Lubrication

All new BLOC range of worm geared motors have lubrication for life with type and quantity of accurate lubricant for its usage in any of mounting position thereby doing away with any maintenance process.

Tabla de potencias mecánicas Power rating

para clase de servicio I (8-10 hs./día sin sobrecargas)
for uniform load (8-10 hour/day)

Velocidad de salida Output speed (rpm)	Velocidad de entrada Input speed (rpm)	Relación nominal Ratio	Rendimiento teórico Efficiency	B50		B63		B76		B100	
				Potencia Input power (HP)	Potencia Input power (HP)	Potencia Input power (HP)	Potencia Input power (HP)	Potencia Input power (HP)	Potencia Input power (HP)		
180	1800	10	0.86	1.31	2.12	3.86	6.69				
150	1500			1.21	1.98	3.60	5.98				
120	1200			1.07	1.79	3.28	5.57				
100	1000			0.95	1.62	2.99	5.34				
90	900			0.89	1.52	2.82	5.07				
75	750	0.78	1.36	2.51	4.80						
90	1800	20	0.79	0.87	1.60	2.54	4.39				
75	1500			0.81	1.47	2.38	4.00				
60	1200			0.72	1.19	2.16	3.70				
50	1000			0.65	1.08	1.96	3.41				
45	900			0.60	1.02	1.85	3.25				
37.5	750	0.53	0.90	1.67	2.94						
60	1800	30	0.67	0.66	1.02	1.74	3.03				
50	1500			0.61	0.94	1.64	3.00				
40	1200			0.55	0.77	1.50	2.57				
33	1000			0.50	0.71	1.39	2.40				
30	900			0.47	0.67	1.31	2.30				
25	750	0.41	0.60	1.19	2.11						
45	1800	40	0.66	0.52	0.80	1.39	2.48				
38	1500			0.49	0.75	1.31	2.29				
30	1200			0.43	0.68	1.22	2.13				
25	1000			0.40	0.61	1.12	2.00				
23	900			0.38	0.59	1.06	1.91				
18.8	750	0.33	0.52	0.96	1.76						
36	1800	50	0.60	0.41	0.68	1.20	2.10				
30	1500			0.39	0.64	1.13	2.00				
24	1200			0.35	0.59	1.04	1.73				
20	1000			0.32	0.53	0.95	1.60				
18	900			0.31	0.50	0.90	1.54				
15	750	0.28	0.46	0.82	1.40						
30	1800	60	0.53	0.34	0.46	0.97	1.59				
25	1500			0.32	0.44	0.92	1.51				
20	1200			0.29	0.41	0.85	1.40				
17	1000			0.27	0.40	0.77	1.31				
15	900			0.25	0.38	0.74	1.24				
12.5	750	0.23	0.35	0.68	1.13						
23	1800	80	0.49	0.25	0.42	0.69	1.15				
19	1500			0.23	0.39	0.64	1.05				
15	1200			0.20	0.36	0.59	1.01				
13	1000			0.18	0.33	0.55	0.93				
11	900			0.17	0.32	0.52	0.89				
9.4	750	0.15	0.28	0.48	0.81						

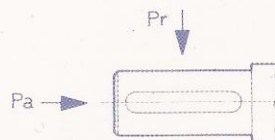

Pr: Carga radial aplicada en el medio del eje de salida. (kg)

Radial load at midpoint of shaft extension. (kg)

Pa: Carga axial. (kg)

Axial load. (kg)

Cargas Sobre el Eje de Salida / Overhung Load

Velocidad de salida Output speed r.p.m.	Tamaño / size							
	B50		B63		B76		B100	
	Pr	Pa	Pr	Pa	Pr	Pa	Pr	Pa
<20	175	79	294	132	455	205	710	331
20...40	158	71	277	124	420	189	680	307
41...60	126	57	214	96	325	146	530	238
61...80	105	47	182	82	277	124	450	202
81...100	95	43	165	74	250	113	410	184
101...120	88	39	154	69	238	107	390	176
121...150	84	38	147	66	224	100	365	165
>150	77	35	140	63	210	95	350	160

Dimensiones externas Overall dimensions

	Modelo Model			
	B50	B63	B76	B100
D1	14	19	24	28
L1	30	40	50	60
chav1/key1	5x5	6x6	8x7	8x7
D2	20	25	30	40
L2	110	130	150	200
chav2/key2	6x6	8x7	8x7	12x8
H0	35	42	49	55
H1	110	133	161	215
H2	60	70	85	115
A	80	95	110	145
B	80	100	120	160
J	105	125	150	190
S	7	9	11	14
I	20	25	30	40
Q0	60	75	90	120
Q	75	90	110	140
Q1	78	92	112	145
R2	115	130	165	215
S2	9	9	12	14
V	20	25	30	40
W	55	65	75	100
W1	73	85	95	125
Y	18	20	20	25
a2	140	160	200	250
c	7	8	10	12
c2	7	8	10	12
e	100	120	140	185
f	120	150	180	240
h	145	175	210	270
Peso	3.5 kg.	6.5 kg.	10.5 kg.	22 kg.

Posiciones de montaje Mounting positions

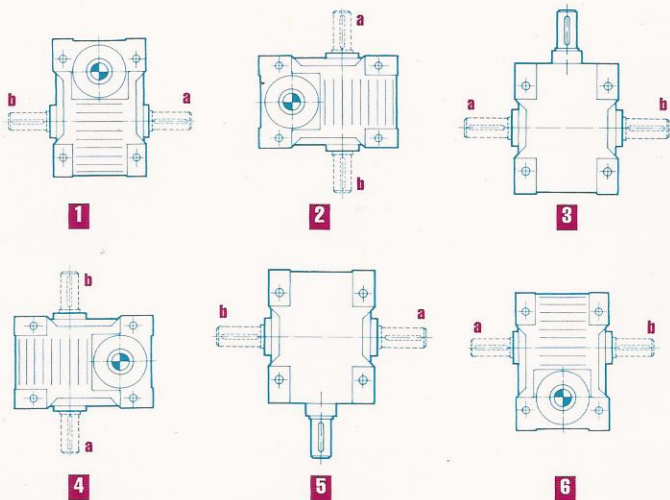

Nota: Para montaje con brida anteponer la letra "B"
Para doble eje de salida indicar con letras "a b"
Note: For flange mounted write "B" before mounting position
For double output shaft write "a b" after mounting position.

Reductor/Worm Gear Box

Montaje con patas/Foot mounted

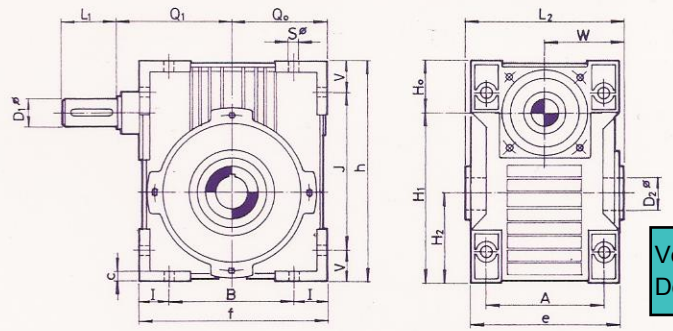

Ver más
Detalles

Montaje con brida/Flange mounted

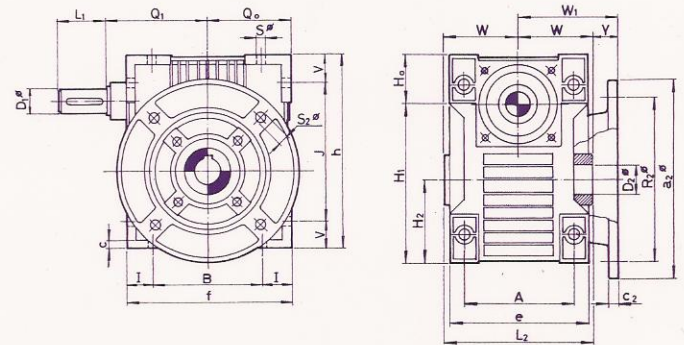

Motorreductor Worm geared motor

Montaje con patas/Foot mounted

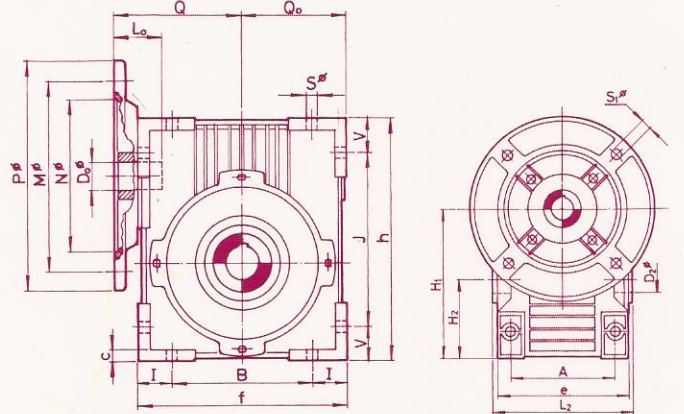

Montaje con brida/Flange mounted

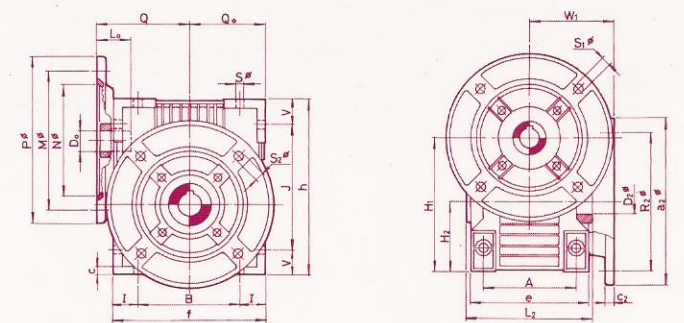

Nota: Para dimensiones P, M, N, D0, L0, S1 ver
catálogo de motores (I.E.C.)
Note: To determinate P, M, N, D0, L0, S1 see electrical
motor catalog (I.E.C.)

Dimensiones ejes de salida / Output shafts dimensions

Eje hueco Shaft mounted

Modelo Model	D3 (H7)	P	Q	d
B50	20	6	22.8	30
B63	25	8	28.3	40
B76	30	8	33.3	50
B100	40	12	43.3	60

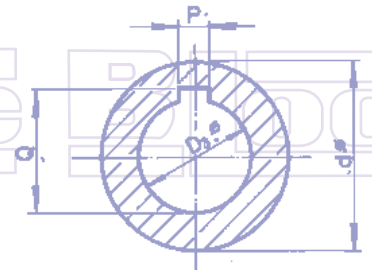

Eje de salida simple Single output shaft

Modelo Model	D3 (k6)	L3 (k6)	Chav 3 Key section	F	LA	LT	Peso Weight (kg)
B50	19	40	6x6	5	115	160	0.37
B63	24	50	8x7	5	135	190	0.69
B76	28	60	8x7	5	155	220	1.15
B100	38	80	10x8	10	205	295	2.75

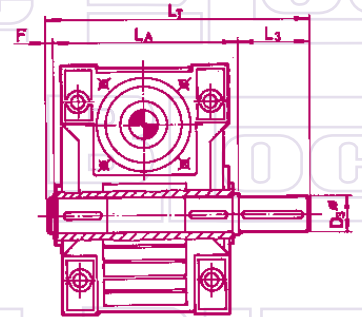

Eje de salida doble Double output shaft

Modelo Model	D3 (k6)	L3 (k6)	Chav 3 Key section	LA	LT	Peso Weight (kg)
B50	19	40	6x6	120	200	0.46
B63	24	50	8x7	140	240	0.86
B76	28	60	8x7	160	280	1.45
B100	38	80	10x8	210	370	3.40

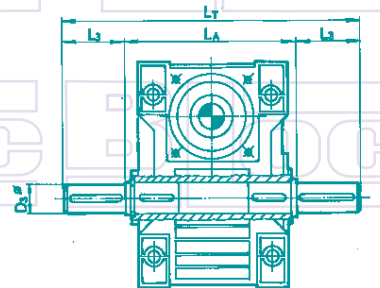

Designación/How to order

Modelo Model	Motor Motor	Relación Ratio	Posición de montaje Mounting position	Kit Kit			
Ejemplo Example	B76	90	10/1	B1a	xxx		
Ejecución Style	Tamaño Size	Tamaño de motor Frame size for I.E.C. motors	Relación nominal o Velocidad de salida Ratio or Output speed	Brida de salida Flange Mount (B)	Equipo base Basic unit 1-2-3-4-5-6	Eje de salida simple Single output shaft a-b	Accesorios Accessories
B: Motorreductor Worm/geared motor MB: Brida para motor Motor flange RB: Reductor Worm gear box	50-63-76-100	71-80-90-100-112				Eje de salida doble Double output shaft ab	

LENTAX – LINEA BLOC

DETALLE DE CARA DE SALIDA

VOLVER

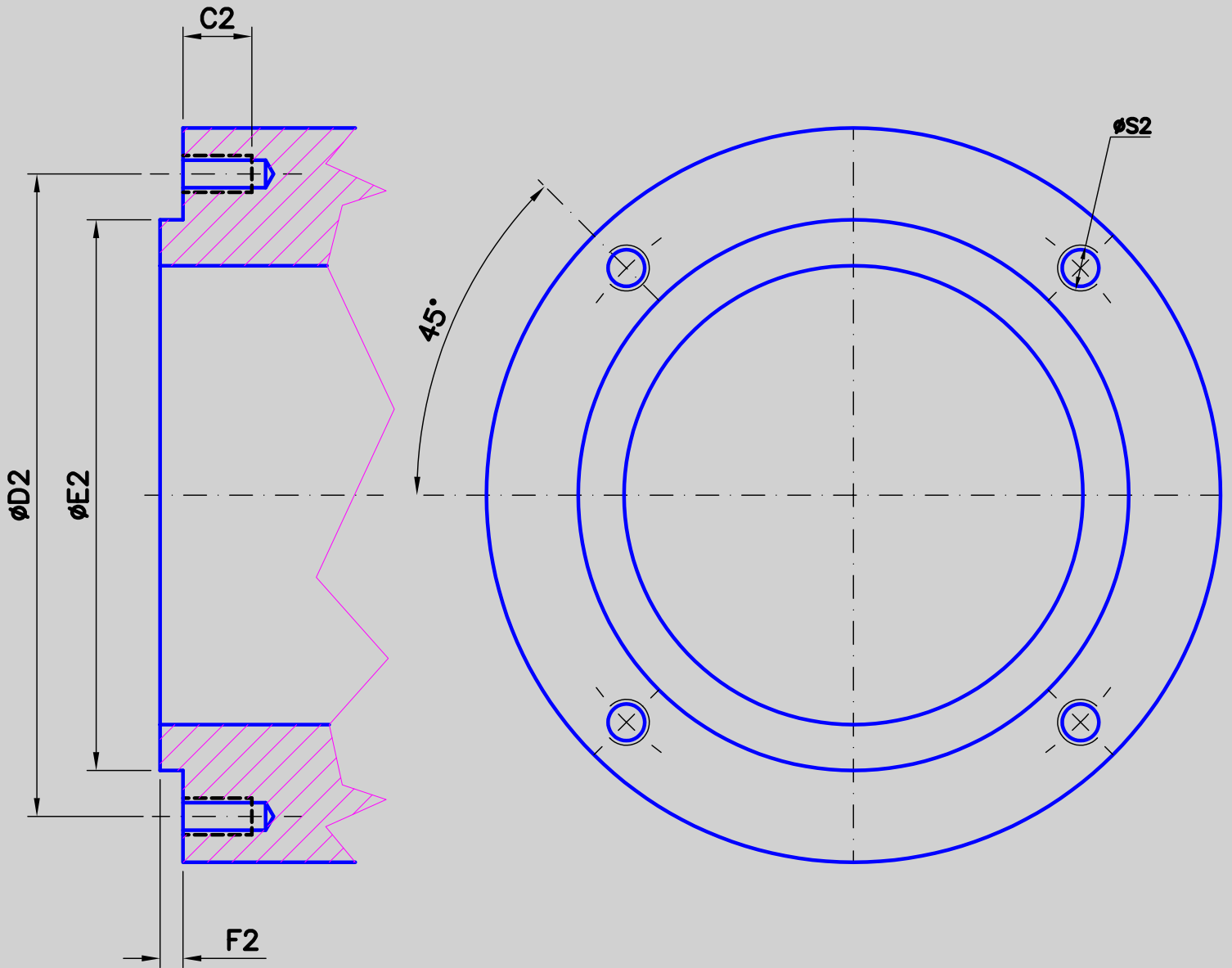

	$\phi D2$	$\phi E2$	$\phi F2$	$\phi S2$	$\phi C2$
B50	65	50.8	2	1/4"W	10
B63	78	62.7	3	1/4"W	12
B76	100	80.5	5	5/16"W	12
B100	115	90.6	5	5/16"W	15



PRODUCTOS RESPALDADOS POR CINCUENTA AÑOS DE EXPERIENCIA Y EVOLUCIÓN

Austria Norte 1158 Tigre - Buenos Aires - Argentina

- Tel. 054-11-5252-1940 (líneas rotativas)
- E-mail: ventas@lentax.com
- web [HTTP://www.lentax.com](http://www.lentax.com)